

T8xx series TRIACS

GENERAL DESCRIPTION :

High current density due to single mesa technology; Glass Passivation. T8xx series triacs is suitable for general purpose AC switching. They can be used as an ON/OFF Function in applications such as static relays, heating regulation motor starting circuits...or for phase control operation light dimmers, motor speed controllers. T8xx series are 3 Quadrants triacs. They are specially recommended for use on inductive loads.

Main Features:

$I_{T(RMS)}$	V_{DRM}/V_{RRM}	V_{TM}
8A	600V and 800 V	≤ 1.5 V

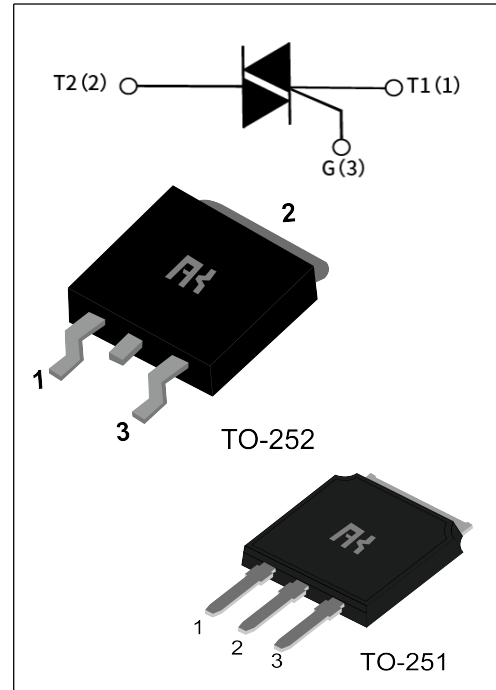

Absolute Ratings(limiting values) :

Symbol	Parameter	Value	Unit
T_{stg}	Storage junction temperature range	- 40 to + 125	°C
T_j	Operating junction temperature range	- 40 to +125	°C
$I_{T(RMS)}$	RMS on-state current TO-251/252 ($T_C=100^\circ\text{C}$)	8	A
I_{TSM}	Non repetitive surge peak on-state current (full cycle, F=50Hz)	80	A
V_{DRM}	Repetitive peak off-state voltage($T_j=25^\circ\text{C}$)	600 and 800	V
V_{RRM}	Repetitive peak reverse voltage($T_j=25^\circ\text{C}$)	600 and 800	V
V_{DSM}	Non repetitive surge peak Off-state voltage	$V_{DRM} + 100$	V
V_{RSM}	Non repetitive peak reverse voltage	$V_{RRM} + 100$	V
I^2t	I^2t value for fusing $t_p = 10$ ms	32	A^2s

dI/dt	Critical rate of rise of on-state current ($I_G = 2 \times I_{GT}$)	50	A/ μ s
I_{GM}	Peak gate current	4	A
P_{G(AV)}	Average gate power dissipation	1	W
P_{GM}	Peak gate power	5	W

Electrical Characteristics : (T_j=25°C unless otherwise specified)

Symbol	Test Condition	Quadrant	Range	Value				Unit
				T605	T610	T625	T650	
I_{GT}	V _D =12V R _L =33Ω	I-II-III	MAX	5	10	25	50	mA
V_{GT}		I-II-III	MAX	1.5				V
V_{GD}	V _D =V _{DRM} R _L =3.3kΩ T _j =150°C	I-II-III	MIN	0.2				V
I_L	I _G =1.2 I _{GT}	I-III	MAX	20	25	50	70	mA
		II		25	35	70	90	
I_H	I _{TM} = 100mA		MAX	15	20	40	60	mA
dV/dt	V _D =2/3V _{DRM} R _{GK} =1kΩ T _j =150°C		MIN	50	200	500	1000	V/ μ s
(dV/dt)_c	(dI/dt) _c =-2.6A/ms T _j =150°C		MIN	1	5	15	25	V/ μ s

Static Characteristics

Symbol	Parameter	Value(MAX)	Unit	
V_{TM}	I _{TM} =5.5A tp= 380 μ s	T _j =25°C	1.5	V
I_{DRM} I_{RRM}	V _D =V _{DRM} , V _R =V _{RRM}	T _j =25°C	5	μ A
		T _j =125°C	1	mA

Thermal Resistances :

Symbol	Parameter	Value	Unit	
R_{th(j-c)}	Junction to case for AC	TO-251/252	2.1	°C/W

FIG.1: Maximum power dissipation versus RMS on-state current

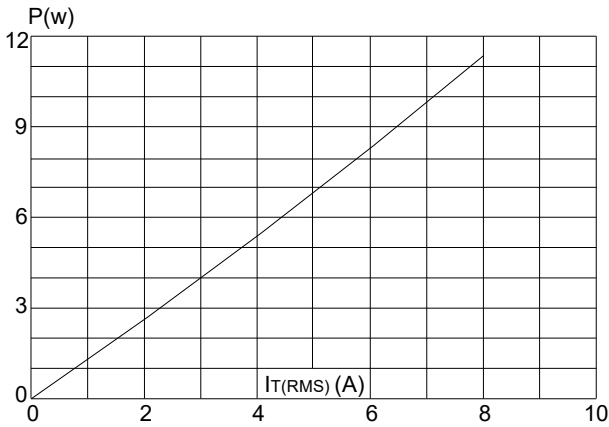

FIG.3: Surge peak on-state current versus number of cycles

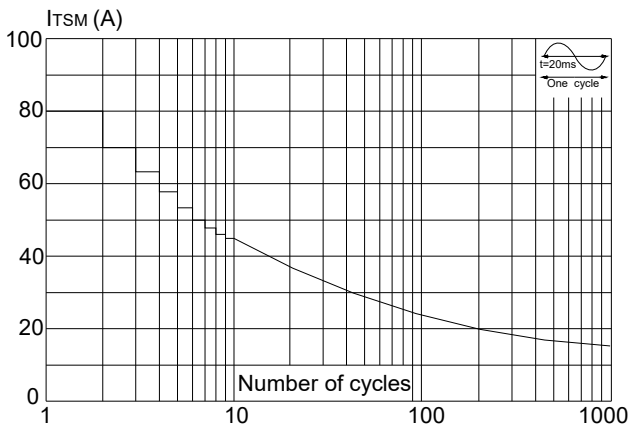

FIG.5: Non-repetitive surge peak on-state current for a sinusoidal pulse with width $t_p < 20\text{ms}$, and corresponding value of I^2t ($di/dt < 50\text{A}/\mu\text{s}$)

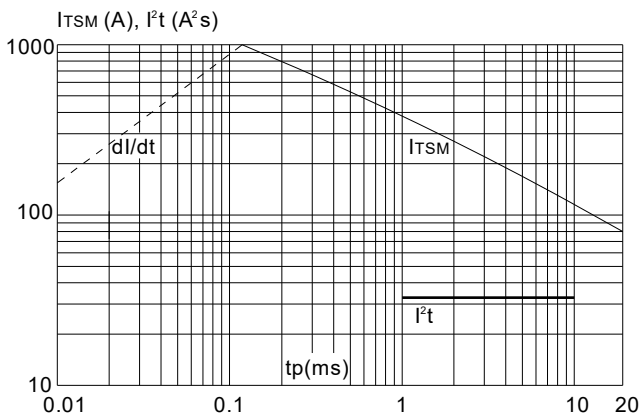

FIG.2: RMS on-state current versus case temperature

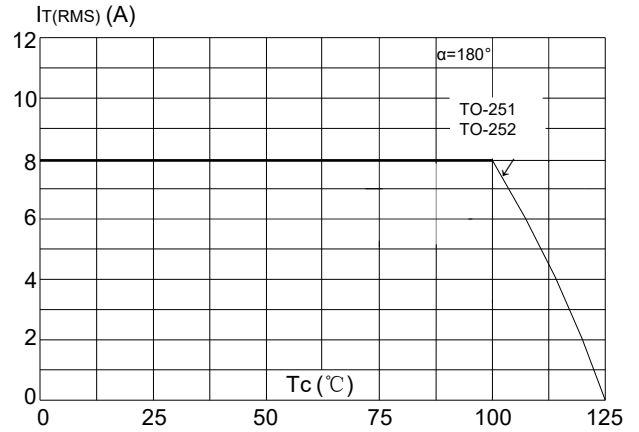

FIG.4: On-state characteristics (maximum values)

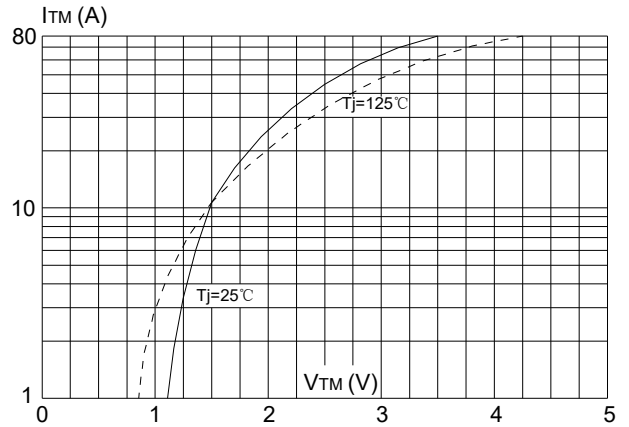
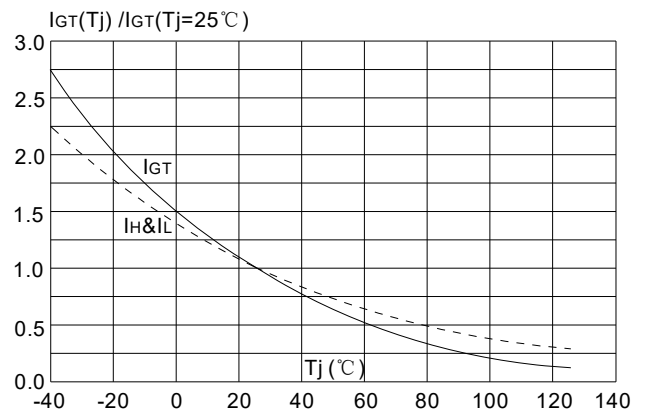
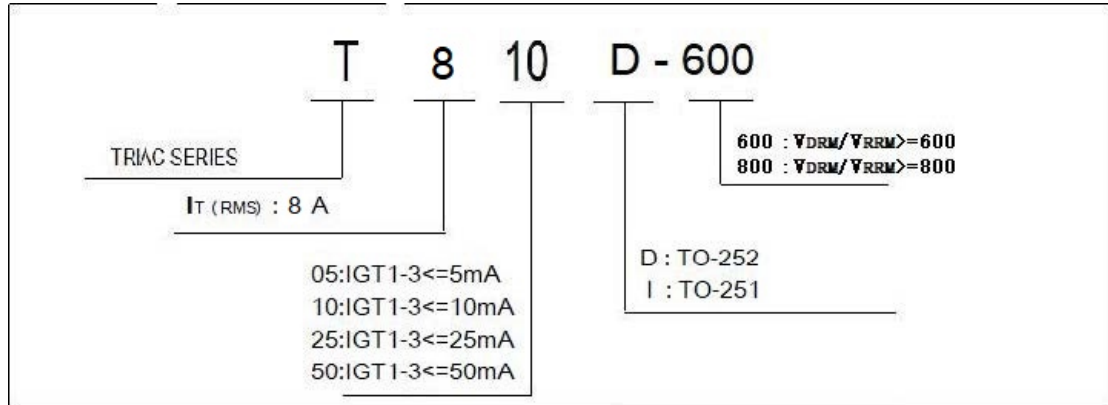

FIG.6: Relative variations of gate trigger current, holding current and latching current versus junction temperature



Ordering Information:



Package Mechanical Data :

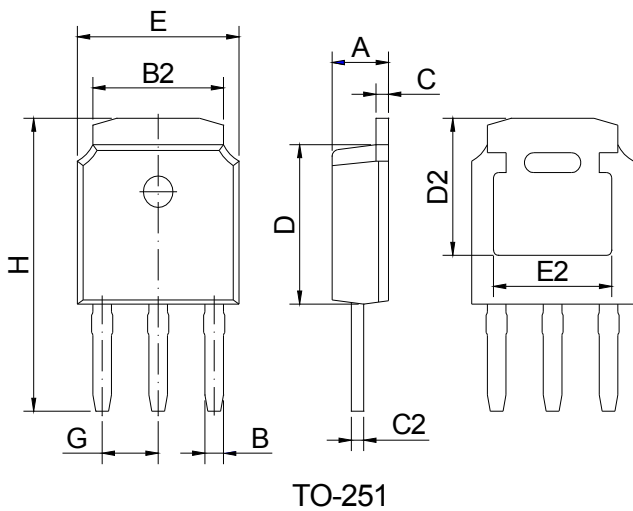

Ref.	Dimensions					
	Millimeters			Inches		
	Min.	Typ.	Max.	Min.	Typ.	Max.
A	2.10	2.30	2.50	0.083	0.091	0.098
B	0.66	0.76	0.86	0.026	0.030	0.034
B2	5.15	5.33	5.48	0.203	0.210	0.216
C	0.44	0.51	0.58	0.017	0.020	0.023
C2	0.44	0.51	0.58	0.017	0.020	0.023
D	5.90	6.10	6.30	0.232	0.240	0.248
D2	5.30 REF			0.209 REF		
E	6.40	6.60	6.80	0.252	0.260	0.268
E2	4.83 REF			0.190 REF		
G	2.19	2.29	2.39	0.086	0.090	0.094
H	10.60	11.20	11.80	0.417	0.441	0.465

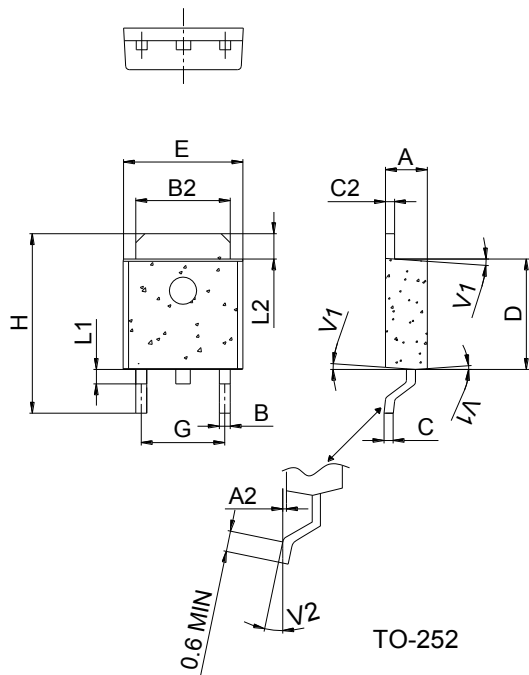

Ref.	Dimensions					
	Millimeters			Inches		
	Min.	Typ.	Max.	Min.	Typ.	Max.
A	2.20		2.40	0.086		0.095
A2	0.03		0.23	0.001		0.009
B	0.55		0.65	0.022		0.026
B2	5.10		5.40	0.200		0.213
C	0.45		0.62	0.018		0.024
C2	0.48		0.62	0.019		0.024
D	6.00		6.20	0.236		0.244
E	6.40		6.70	0.252		0.264
G	4.40		4.70	0.173		0.185
H	9.35		10.6	0.368		0.417
L1	1.30		1.70	0.051		0.067
L2	1.37		1.50	0.054		0.059
V1		4°			4°	
V2	0°		8°	0°		8°

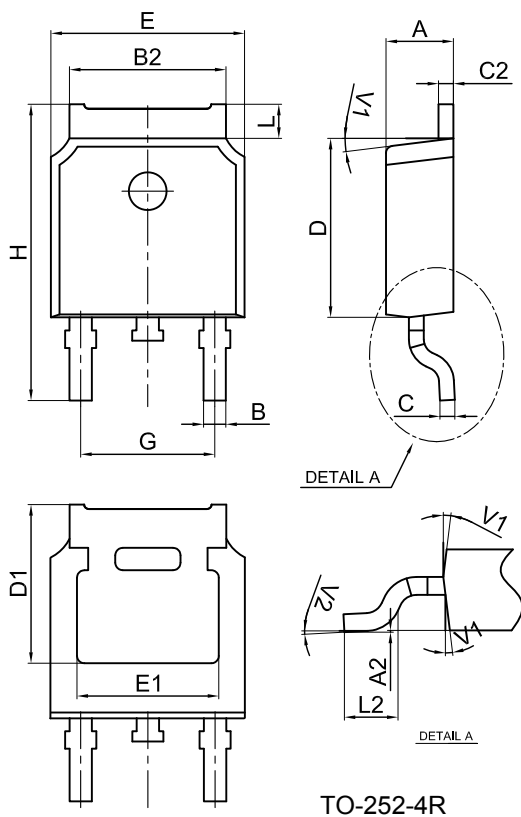

Ref.	Dimensions					
	Millimeters			Inches		
	Min.	Typ.	Max.	Min.	Typ.	Max.
A	2.10		2.50	0.083		0.098
A2	0		0.10	0		0.004
B	0.66		0.86	0.026		0.034
B2	5.18		5.48	0.202		0.216
C	0.40		0.60	0.016		0.024
C2	0.44		0.58	0.017		0.023
D	5.90		6.30	0.232		0.248
D1	5.30REF			0.209REF		
E	6.40		6.80	0.252		0.268
E1	4.63			0.182		
G	4.47		4.67	0.176		0.184
H	9.50		10.70	0.374		0.421
L	1.09		1.21	0.043		0.048
L2	1.35		1.65	0.053		0.065
V1		7°			7°	
V2	0°		6°	0°		6°