

## T6xx series TRIACS

### GENERAL DESCRIPTION:

High current density due to single mesa technology; Glass Passivation. T6xx series triacs are suitable for general purpose AC switching. They can be used as an ON/OFF function in applications such as static relays, heating regulation motor starting circuits...or for phase control operation light dimmers, motor speed controllers. T6xx series are 3 Quadrants triacs. They are specially recommended for use on inductive loads.

### Main Features:

$I_{T(RMS)}$	$V_{DRM}/V_{RRM}$	$V_{TM}$
6A	600V and 800 V	$\leq 1.5 V$

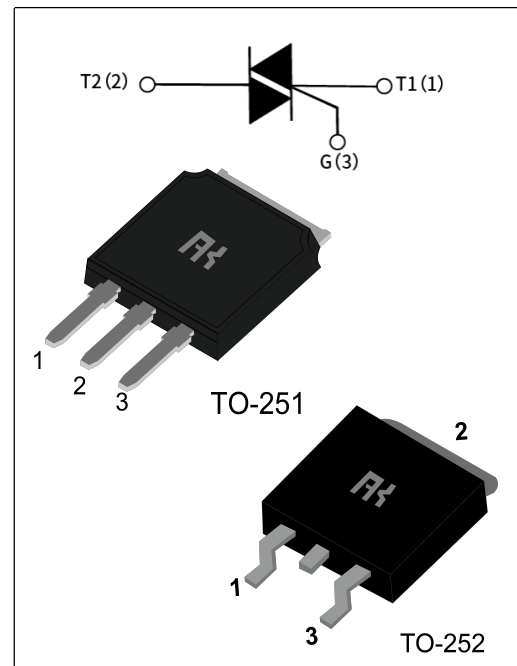

### Absolute Ratings(limiting values) :

Symbol	Parameter	Value	Unit
$T_{stg}$	Storage junction temperature range	- 40 to + 125	$^{\circ}C$
$T_j$	Operating junction temperature range	- 40 to +125	$^{\circ}C$
$I_{T(RMS)}$	RMS on-state current TO-251/252 ( $T_C=100^{\circ}C$ )	6	A
$I_{TSM}$	Non repetitive surge peak on-state current (full cycle, F=50Hz)	60	A
$V_{DRM}$	Repetitive peak off-state voltage( $T_j=25^{\circ}C$ )	600 and 800	V
$V_{RRM}$	Repetitive peak reverse voltage( $T_j=25^{\circ}C$ )	600 and 800	V
$V_{DSM}$	Non repetitive surge peak Off-state voltage	$V_{DRM} + 100$	V
$V_{RSM}$	Non repetitive peak reverse voltage	$V_{RRM} + 100$	V
$I^2t$	$I^2t$ value for fusing $t_p = 10 ms$	18	$A^2s$

<b>dI/dt</b>	Critical rate of rise of on-state current ( $I_G = 2 \times I_{GT}$ )	50	A/ $\mu$ s
<b>I<sub>GM</sub></b>	Peak gate current	2	A
<b>P<sub>G(AV)</sub></b>	Average gate power dissipation	1	W
<b>P<sub>GM</sub></b>	Peak gate power	5	W

**Electrical Characteristics : (T<sub>j</sub>=25°C unless otherwise specified)**

Symbol	Test Condition	Quadrant	Range	Value				Unit
				T605	T610	T625	T650	
<b>I<sub>GT</sub></b>	V <sub>D</sub> =12V R <sub>L</sub> =33Ω	I-II-III	MAX	5	10	25	50	mA
<b>V<sub>GT</sub></b>		I-II-III	MAX	1.5				V
<b>V<sub>GD</sub></b>	V <sub>D</sub> =V <sub>DRM</sub> R <sub>L</sub> =3.3kΩ T <sub>j</sub> =150°C	I-II-III	MIN	0.2				V
<b>I<sub>L</sub></b>	I <sub>G</sub> =1.2 I <sub>GT</sub>	I-III	MAX	10	20	50	70	mA
		II		15	25	60	80	
<b>I<sub>H</sub></b>	I <sub>TM</sub> = 100mA		MAX	10	15	35	60	mA
<b>dV/dt</b>	V <sub>D</sub> =2/3V <sub>DRM</sub> R <sub>GK</sub> =1kΩ T <sub>j</sub> =150°C		MIN	50	100	400	1000	V/ $\mu$ s
<b>(dV/dt)<sub>c</sub></b>	(dI/dt) <sub>c</sub> =-2.6A/ms T <sub>j</sub> =150°C		MIN	1	5	15	25	V/ $\mu$ s

**Static Characteristics**

Symbol	Parameter	Value(MAX)	Unit	
<b>V<sub>TM</sub></b>	I <sub>TM</sub> =5.5A tp= 380 $\mu$ s	T <sub>j</sub> =25°C	1.5	V
<b>I<sub>DRM</sub></b> <b>I<sub>RRM</sub></b>	V <sub>D</sub> =V <sub>DRM</sub> , V <sub>R</sub> =V <sub>RRM</sub>	T <sub>j</sub> =25°C	5	$\mu$ A
		T <sub>j</sub> =125°C	1	mA

**Thermal Resistances :**

Symbol	Parameter	Value	Unit	
<b>R<sub>th(j-c)</sub></b>	Junction to case for AC	TO-251/252	2.4	°C/W

**FIG.1:** Maximum power dissipation versus RMS on-state current(full cycle)

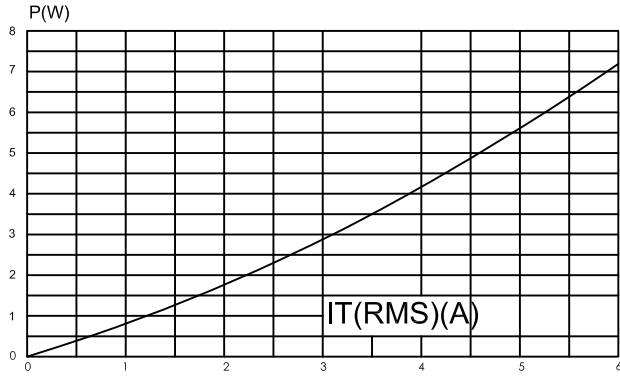

**FIG.2:** RMS on-state current versus case temperature(full cycle)

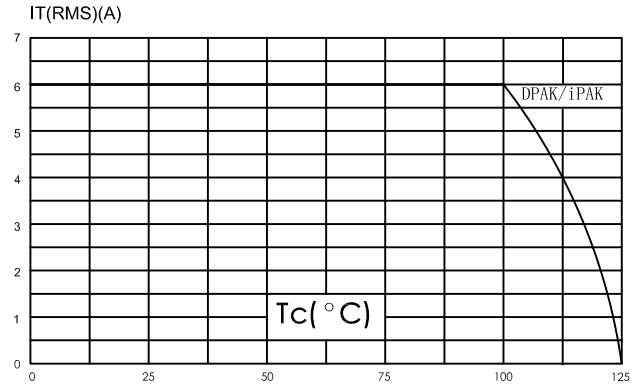

**FIG.3:** On-state characteristics (maximum values)

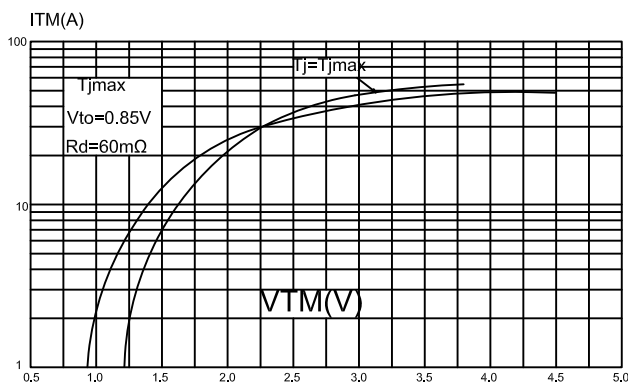

**FIG.4:** Surge peak on-state current versus number of cycles

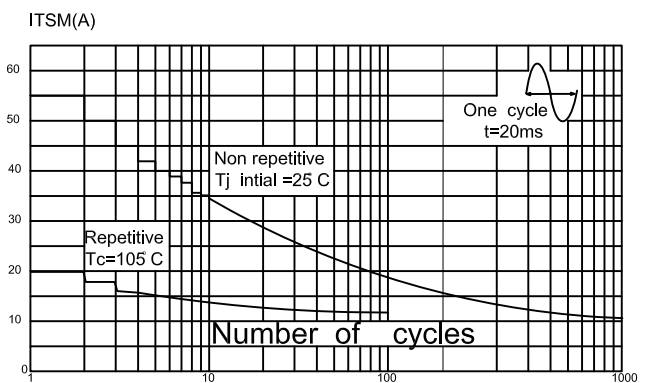

**FIG.5:** Non-repetitive surge peak on-state current for a sinusoidal pulse with width  $t_p < 10\text{ms}$ , and corresponding value of  $I \cdot t$ .

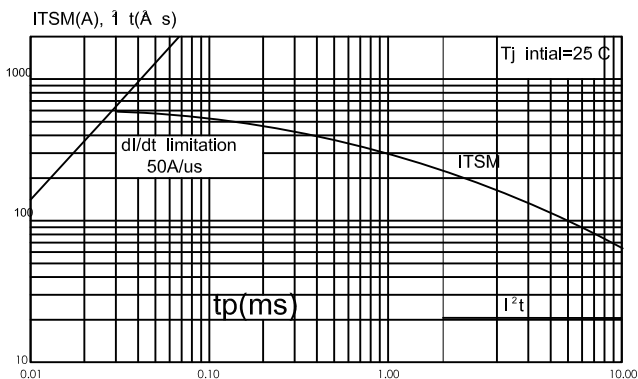

**FIG.6:** Relative variations of gate trigger current, holding current and latching current versus junction temperature(typical values)

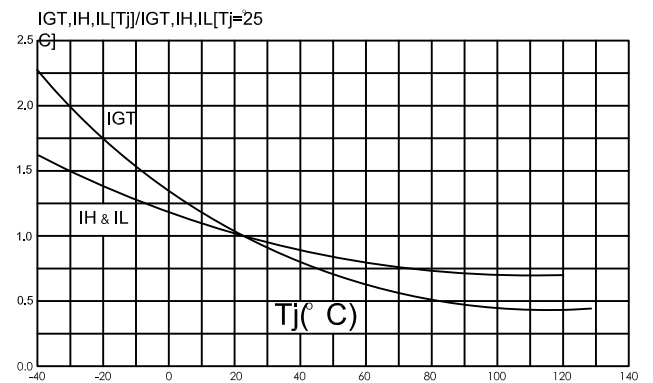

**Ordering Information:**

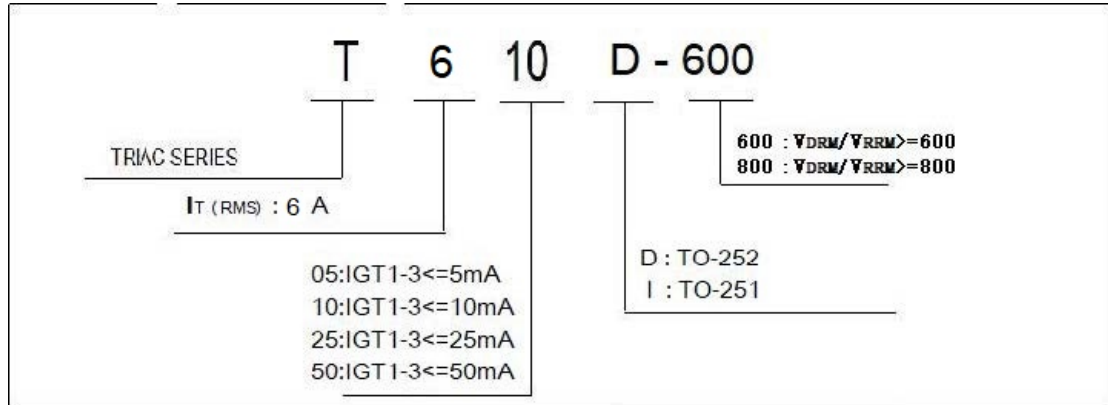

**Package Mechanical Data :**

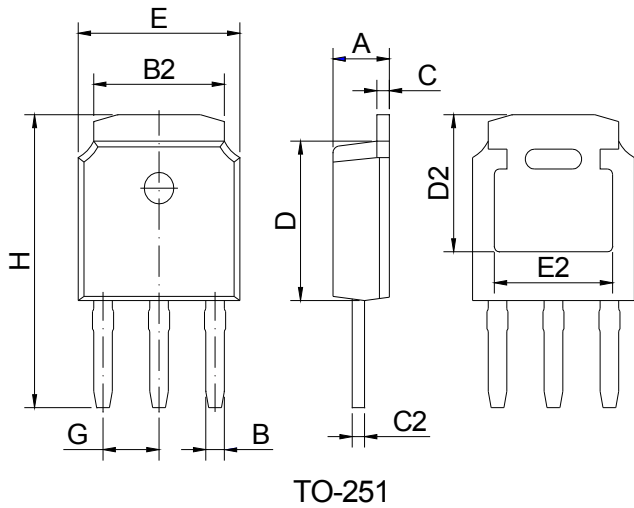

Ref.	Dimensions					
	Millimeters			Inches		
	Min.	Typ.	Max.	Min.	Typ.	Max.
A	2.10	2.30	2.50	0.083	0.091	0.098
B	0.66	0.76	0.86	0.026	0.030	0.034
B2	5.15	5.33	5.48	0.203	0.210	0.216
C	0.44	0.51	0.58	0.017	0.020	0.023
C2	0.44	0.51	0.58	0.017	0.020	0.023
D	5.90	6.10	6.30	0.232	0.240	0.248
D2	5.30 REF			0.209 REF		
E	6.40	6.60	6.80	0.252	0.260	0.268
E2	4.83 REF			0.190 REF		
G	2.19	2.29	2.39	0.086	0.090	0.094
H	10.60	11.20	11.80	0.417	0.441	0.465

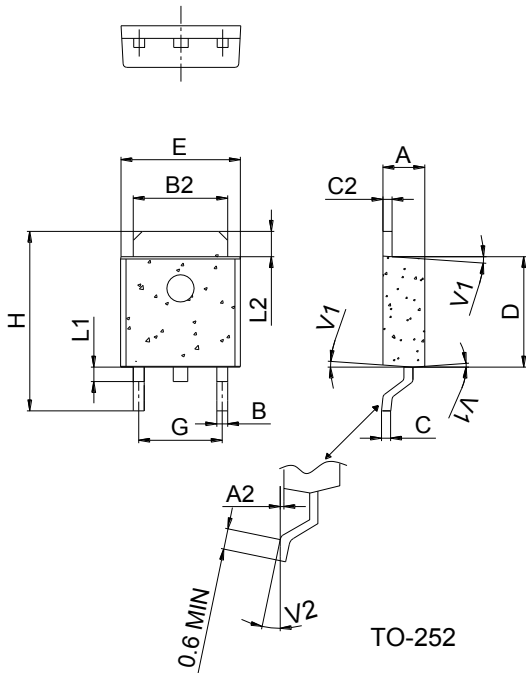

Ref.	Dimensions					
	Millimeters			Inches		
	Min.	Typ.	Max.	Min.	Typ.	Max.
A	2.20		2.40	0.086		0.095
A2	0.03		0.23	0.001		0.009
B	0.55		0.65	0.022		0.026
B2	5.10		5.40	0.200		0.213
C	0.45		0.62	0.018		0.024
C2	0.48		0.62	0.019		0.024
D	6.00		6.20	0.236		0.244
E	6.40		6.70	0.252		0.264
G	4.40		4.70	0.173		0.185
H	9.35		10.6	0.368		0.417
L1	1.30		1.70	0.051		0.067
L2	1.37		1.50	0.054		0.059
V1		4°			4°	
V2	0°		8°	0°		8°

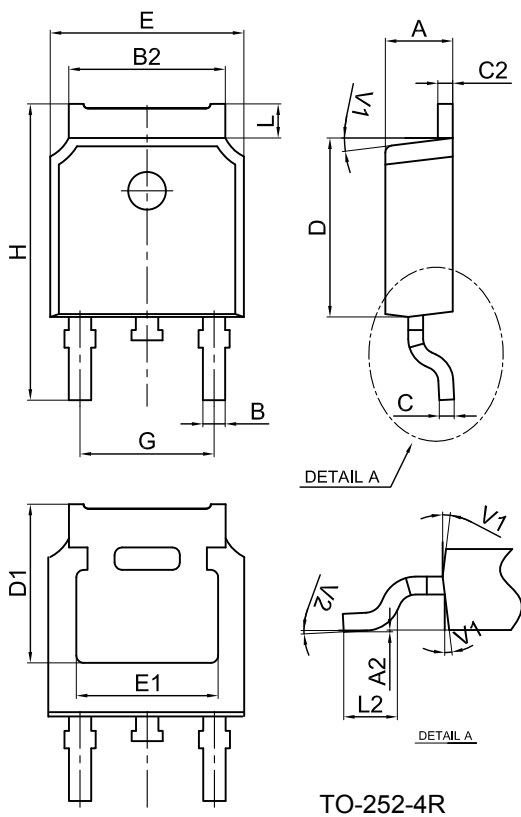

Ref.	Dimensions					
	Millimeters			Inches		
	Min.	Typ.	Max.	Min.	Typ.	Max.
A	2.10		2.50	0.083		0.098
A2	0		0.10	0		0.004
B	0.66		0.86	0.026		0.034
B2	5.18		5.48	0.202		0.216
C	0.40		0.60	0.016		0.024
C2	0.44		0.58	0.017		0.023
D	5.90		6.30	0.232		0.248
D1	5.30REF			0.209REF		
E	6.40		6.80	0.252		0.268
E1	4.63			0.182		
G	4.47		4.67	0.176		0.184
H	9.50		10.70	0.374		0.421
L	1.09		1.21	0.043		0.048
L2	1.35		1.65	0.053		0.065
V1		7°			7°	
V2	0°		6°	0°		6°