

## BTB20 Serial Standard TRIACS

### GENERAL DESCRIPTION:

High current density due to double mesa technology; Glass Passivation. BTB20 series TRIACS are suitable for general purpose AC switching. They can be used as an ON/OFF Function in applications such as static relays, heating regulation, induction motor starting circuits..or for phase control operation light dimmers, motor speed controllers, etc.

### Main Features:

$I_{T(RMS)}$	$V_{DRM}/V_{RRM}$	$V_{TM}$
20 A	600V 800V	$\leq 1.55$ V

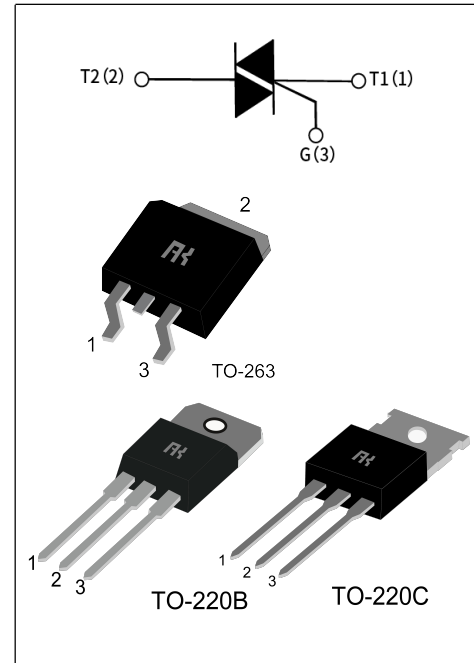

### Absolute Ratings(limiting values) :

Symbol	Parameter		Value	Unit
$T_{stg}$	Storage junction temperature range		- 40 to + 150	$^{\circ}C$
$T_j$	Operating junction temperature range		- 40 to + 125	$^{\circ}C$
$I_{T(RMS)}$	RMS on-state current	TO-220BC(Non-Ins) (TC=90 $^{\circ}C$ )	20	A
		TO-263 (TC=65 $^{\circ}C$ )		
$I_{TSM}$	Non repetitive surge peak on-state current (tp=10ms)		200	A
$V_{DRM}$	Repetitive peak off-state voltage(Tj =25 $^{\circ}C$ )		600/800	V
$V_{RRM}$	Repetitive peak reverse voltage(Tj =25 $^{\circ}C$ )		600/800	V
$V_{DSM}$	Non repetitive surge peak Off-state voltage		$V_{DRM} + 100$	V
$V_{RSM}$	Non repetitive peak reverse voltage		$V_{RRM} + 100$	V
$I^2t$	$I^2t$ value for fusing tp = 10 ms		200	A $^2s$
$dI/dt$	Critical rate of rise of on-state current ( $I_G = 2 \times I_{GT}$ )		100	A/ $\mu s$

<b>I<sub>GM</sub></b>	Peak gate current	4	A
<b>P<sub>G(AV)</sub></b>	Average gate power dissipation	1	W
<b>P<sub>GM</sub></b>	Peak gate power	10	W

**Electrical Characteristics : (T<sub>j</sub>=25°C unless otherwise specified)**

Symbol	Test Condition	Quadrant	Range	V <sub>DRM</sub> /V <sub>R<sub>RRM</sub></sub> : 600/800V		V <sub>DRM</sub> /V <sub>R<sub>RRM</sub></sub> :	Unit
				B	C	1200	
<b>I<sub>GT</sub></b>	V <sub>D</sub> =12V R <sub>L</sub> =33Ω	I-II-III	MAX	50	35	50	mA
<b>V<sub>GT</sub></b>		I-II-III	MAX	1.5			V
<b>V<sub>GD</sub></b>	V <sub>D</sub> =V <sub>DRM</sub> R <sub>L</sub> =3.3kΩ T <sub>j</sub> =125°C	I-II-III	MIN	0.2			V
<b>I<sub>L</sub></b>	I <sub>G</sub> =1.2 I <sub>GT</sub>	I-III	MAX	70	50	80	mA
		II		80	60	100	
<b>I<sub>H</sub></b>	I <sub>TM</sub> = 100mA		MAX	60	40	70	mA
<b>dV/dt</b>	V <sub>D</sub> =2/3V <sub>DRM</sub> Gate Open T <sub>j</sub> =125°C		MIN	500	250	200	V/μs
<b>(dV/dt)<sub>c</sub></b>	(dI/dt) <sub>c</sub> =8.8A/ms T <sub>j</sub> =125°C		MIN	12.5	7	7	V/μs

**Static Characteristics**

Symbol	Parameter		Value(MAX)	Unit
<b>V<sub>TM</sub></b>	I <sub>TM</sub> =28A tp= 380μs	T <sub>j</sub> =25°C	1.55	V
<b>I<sub>DRM</sub></b> <b>I<sub>R<sub>RRM</sub></sub></b>	V <sub>D</sub> =V <sub>DRM</sub> , V <sub>R</sub> =V <sub>R<sub>RRM</sub></sub>	T <sub>j</sub> =25°C	5	μ A
		T <sub>j</sub> =125°C	2.5	mA

**Thermal Resistances :**

Symbol	Parameter		Value	Unit
<b>R<sub>th(j-c)</sub></b>	Junction to case for AC	TO-263	2.5	°C/W
		TO-220BC(Non-Ins)	1.1	

Fig.1: Maximum power dissipation versus RMS on-state current

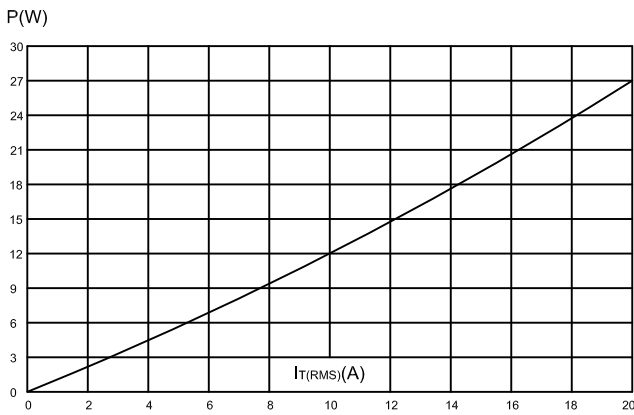

Fig.2 : RMS on-state current versus case temperature

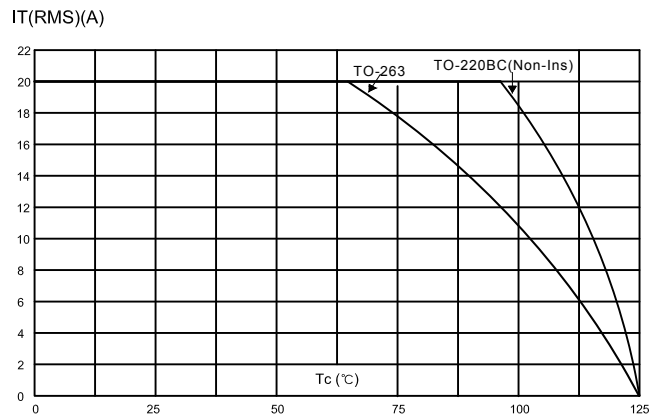

Fig.3 : Surge peak on-state current versus number of cycles

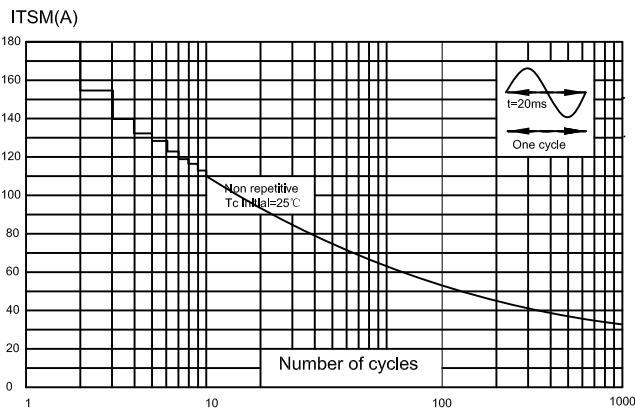

Fig.4 : On-state characteristics (maximum values)

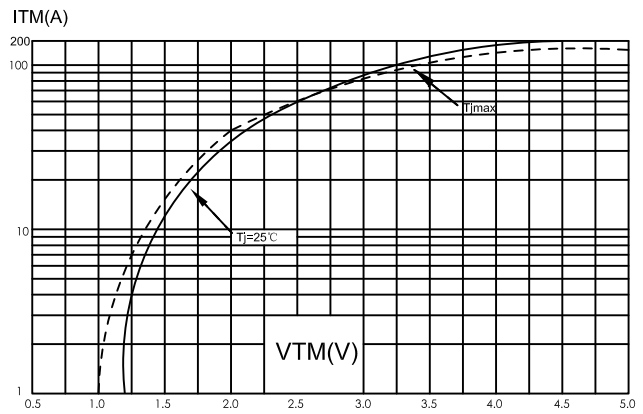

Fig.5 : Non-repetitive surge peak on-state current for a sinusoidal pulse with width  $t_p < 20\text{ms}$  and corresponding value of  $I_t t$  ( $dI/dt < 100\text{A}/\mu\text{s}$ )

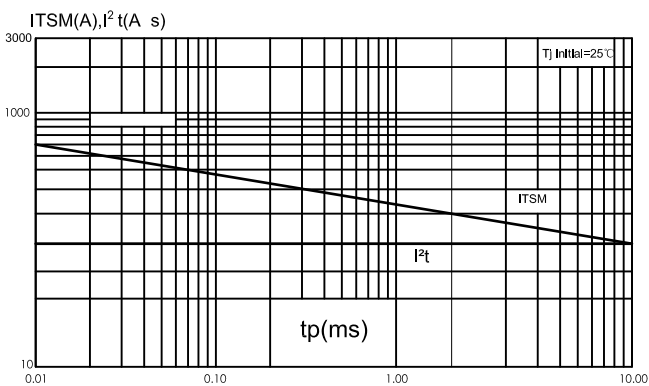
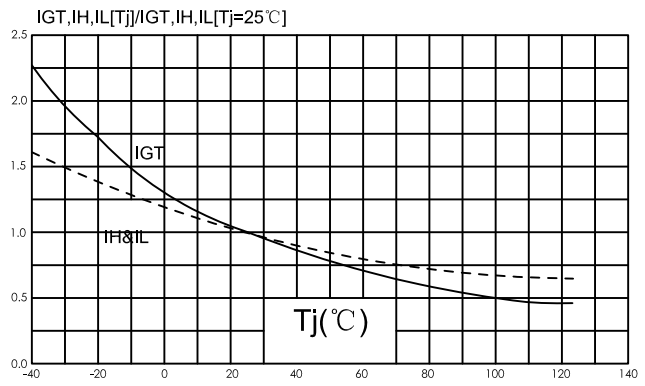
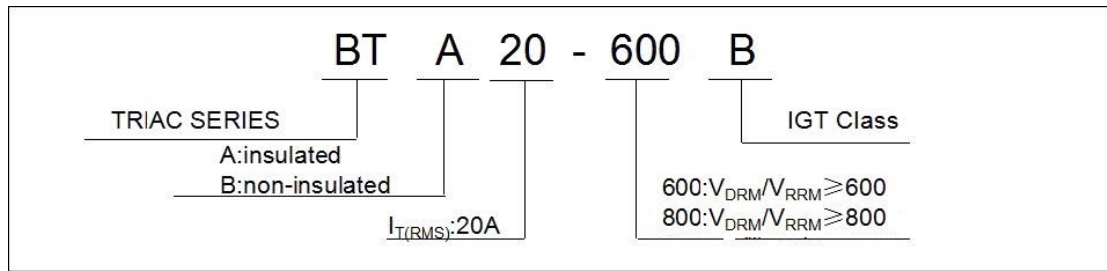
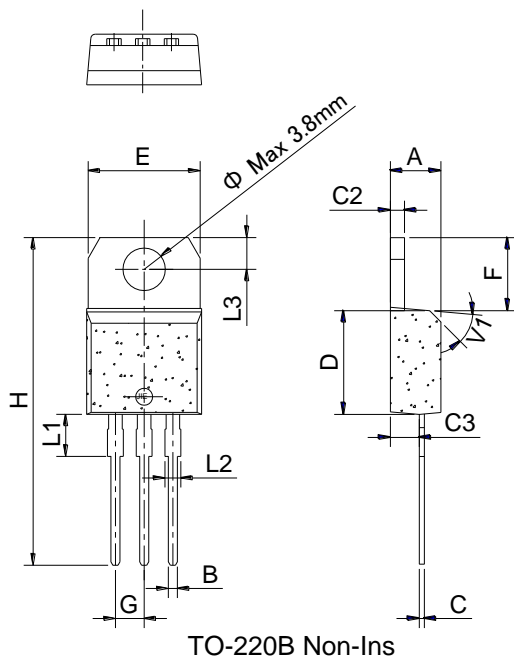
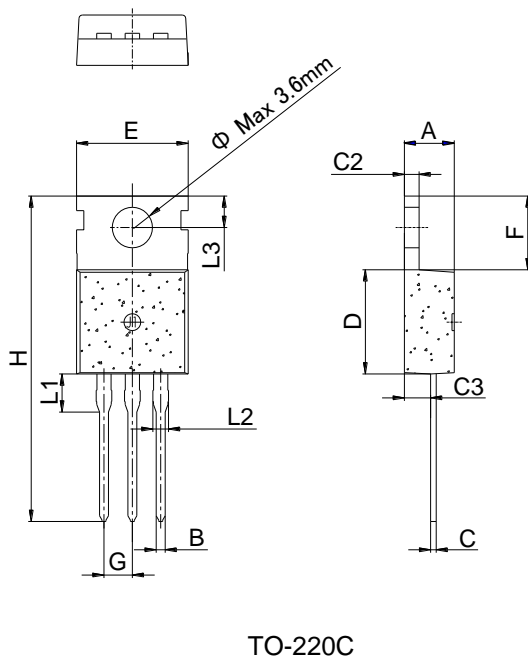

Fig.6: Relative variations of gate trigger current, holding current and latching current versus junction temperature



**Ordering Information:**

**Package Mechanical Data :**

Ref.	Dimensions					
	Millimeters			Inches		
	Min.	Typ.	Max.	Min.	Typ.	Max.
A	4.40		4.60	0.173		0.181
B	0.61		0.88	0.024		0.035
C	0.46		0.70	0.018		0.028
C2	1.21		1.32	0.048		0.052
C3	2.40		2.72	0.094		0.107
D	8.60		9.70	0.339		0.382
E	9.60		10.4	0.378		0.409
F	6.20		6.60	0.244		0.260
G		2.54			0.1	
H	28.0		29.8	1.102		1.173
L1		3.75			0.148	
L2	1.14		1.70	0.045		0.067
L3	2.65		2.95	0.104		0.116
V1		45°			45°	

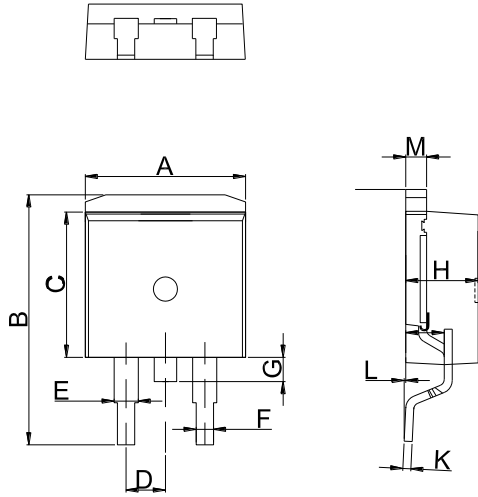

Ref.	Dimensions					
	Millimeters			Inches		
	Min.	Typ.	Max.	Min.	Typ.	Max.
A	4.40		4.60	0.173		0.181
B	0.70		0.90	0.028		0.035
C	0.45		0.60	0.018		0.024
C2	1.23		1.32	0.048		0.052
C3	2.20		2.60	0.087		0.102
D	8.90		9.90	0.350		0.390
E	9.90		10.3	0.390		0.406
F	6.30		6.90	0.248		0.272
G		2.54			0.1	
H	28.0		29.8	1.102		1.173
L1		3.39			0.133	
L2	1.14		1.70	0.045		0.067
L3	2.65		2.95	0.104		0.116
Φ		3.6			0.142	



TO-263

Ref.	Dimensions					
	Millimeters			Inches		
	Min.	Typ.	Max.	Min.	Typ.	Max.
A	9.90		10.20	0.390		0.402
B	14.70		15.80	0.579		0.622
C	9.4		9.6	0.37		0.378
D		2.54			0.100	
E	1.20		1.40	0.047		0.055
F	0.75		0.85	0.029		0.033
G			1.75			0.069
H	4.40		4.70	0.173		0.185
J	2.30		2.70	0.091		0.106
K	0.38		0.55	0.015		0.022
L	0	0.10	0.25	0	0.004	0.010
M	1.25		1.35	0.049		0.053