

## BT139 Serial Standard TRIACS

### GENERAL DESCRIPTION :

High current density due to mesa technology;  
 Glass passivation. BT139 series TRIACS is suitable for general purpose AC switching. They can be used as an ON/OFF Function in applications such as static relays, heating regulation, induction motor starting circuits, or for phase control operation light dimmers, motor speed controllers.

### Main Features:

$I_{T(RMS)}$	$V_{DRM}/V_{RRM}$	$V_{TM}$
16 A	600V and 800V	$\leq 1.6V$

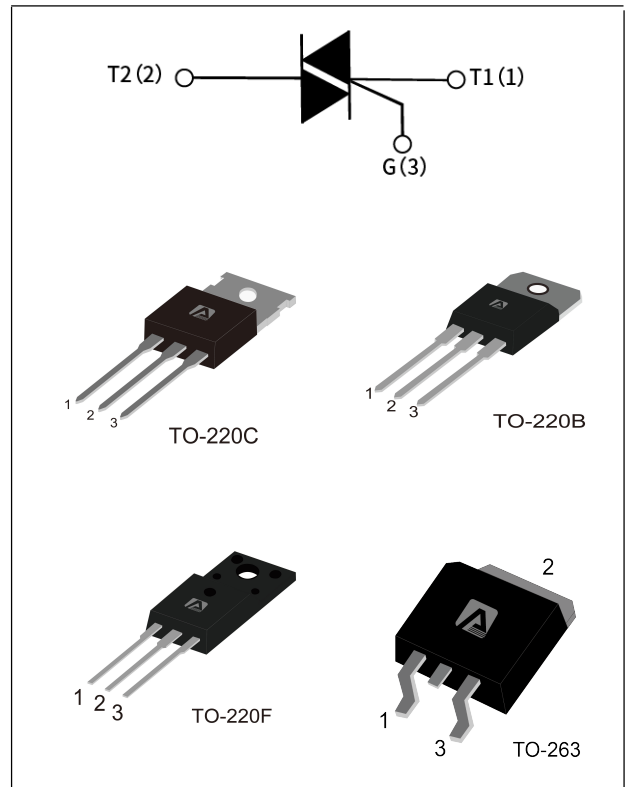

### Absolute Ratings (limiting values) :

Symbol	Parameter	Value	Unit	
$T_{stg}$	Storage junction temperature range	- 40 to + 150	$^{\circ}C$	
$T_j$	Operating junction temperature range	- 40 to + 125	$^{\circ}C$	
$I_{T(RMS)}$	RMS on-state current	TO-220F (TC=85 $^{\circ}C$ )	16	A
		TO-220B/C (TC=100 $^{\circ}C$ )		
		TO-263 (TC=110 $^{\circ}C$ )		
$I_{TSM}$	Non repetitive surge peak on-state current (full cycle, F=50Hz)	140	A	
$V_{DRM}$	Repetitive peak off-state voltage ( $T_j = 25^{\circ}C$ )	600 and 800	V	
$V_{RRM}$	Repetitive peak reverse voltage ( $T_j = 25^{\circ}C$ )	600 and 800	V	
$V_{DSM}$	Non repetitive surge peak Off-state voltage	$V_{DRM} + 100$	V	
$V_{RSM}$	Non repetitive peak reverse voltage	$V_{RRM} + 100$	V	

<b>I<sup>2</sup>t</b>	I <sup>2</sup> t value for fusing tp = 10 ms	98	A <sup>2</sup> s
<b>dI/dt</b>	Critical rate of rise of on-state current (I <sub>G</sub> = 2 × I <sub>GT</sub> )	50	A/μs
<b>I<sub>GM</sub></b>	Peak gate current	2	A
<b>P<sub>G(AV)</sub></b>	Average gate power dissipation	0.5	W
<b>P<sub>GM</sub></b>	Peak gate power	5	W

● **SNUBBERLESS(3 Quadrants)**

Symbol	Test Condition	Quadrant	Range	Value	Unit
				EW	
<b>I<sub>GT</sub></b>	V <sub>D</sub> =12V R <sub>L</sub> =33Ω	I-II-III	MAX	10	mA
<b>V<sub>GT</sub></b>		I-II-III	MAX	1.5	
<b>V<sub>GD</sub></b>	V <sub>D</sub> =V <sub>DRM</sub> T <sub>j</sub> =125°C R <sub>L</sub> =3.3kΩ	I-II-III	MIN	0.2	V
<b>I<sub>L</sub></b>	I <sub>G</sub> =1.2 I <sub>GT</sub>	I-III	TYP	30	mA
		II		40	
<b>I<sub>H</sub></b>	IT= 100mA		MAX	25	mA
<b>dV/dt</b>	V <sub>D</sub> =2/3V <sub>DRM</sub> Gate Open T <sub>j</sub> =125°C		MIN	10	V/μs

● **STANDARD(4 Quadrants)**

Symbol	Test Condition	Quadrant	Range	Value	Unit
				E	
<b>I<sub>GT</sub></b>	V <sub>D</sub> =12V R <sub>L</sub> =33Ω	I-II-III	MAX	10	mA
		IV	MAX	25	
<b>V<sub>GT</sub></b>		I-II-III-IV	MAX	1.5	V
<b>V<sub>GD</sub></b>	V <sub>D</sub> =V <sub>DRM</sub> T <sub>j</sub> =125°C R <sub>L</sub> =3.3kΩ	I-II-III-IV	MIN	0.2	V

<b>I<sub>L</sub></b>	I <sub>G</sub> =1.2 I <sub>GT</sub>	I-III-IV	TYP	30	mA
		II		40	
<b>I<sub>H</sub></b>	I <sub>T</sub> = 100mA		MAX	25	mA
<b>dV/dt</b>	V <sub>D</sub> =2/3V <sub>DRM</sub> Gate Open T <sub>j</sub> =125°C		MIN	10	V/μs

### STATIC CHARACTERISTICS

Symbol	Parameter			Value(MAX)	Unit
<b>V<sub>TM</sub></b>	I <sub>TM</sub> = 20A tp= 380μs	T <sub>j</sub> =25°C	MAX	1.6	V
<b>I<sub>DRM</sub></b> <b>I<sub>RRM</sub></b>	V <sub>D</sub> =V <sub>DRM</sub> ,V <sub>R</sub> =V <sub>RRM</sub>	T <sub>j</sub> =25°C	MAX	5	μ A
		T <sub>j</sub> =125°C		1	mA

### Thermal Resistances :

Symbol	Parameter		Value	Unit
<b>R<sub>th(j-c)</sub></b>	junction to case(AC)	TO-220F (TC=85°C)	3.0	°C/W
		TO-220B/C (TC=100°C)		
		TO-263 (TC=110°C)		

### Ordering Information:

<b>BT 139 - 600 E</b> TRIAC SERIES I <sub>T(RMS)</sub> :16A	E: IGT <sub>1-3</sub> ≤10mA STANDARD EW:IGT <sub>1-3</sub> ≤10mA SNUBBERLESS 600:V <sub>DRM</sub> /V <sub>RRM</sub> ≥600 800:V <sub>DRM</sub> /V <sub>RRM</sub> ≥800
---	---

**FIG.1** Maximum power dissipation versus RMS on-state current

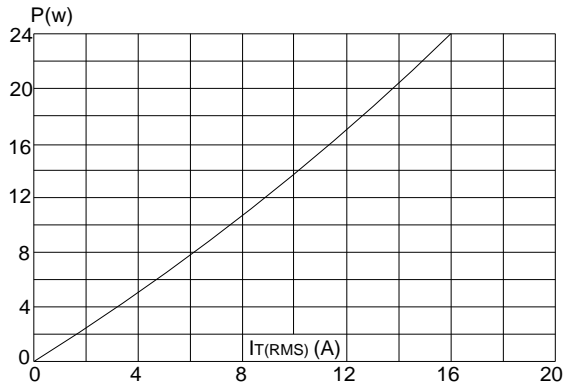

**FIG.2:** RMS on-state current versus case temperature

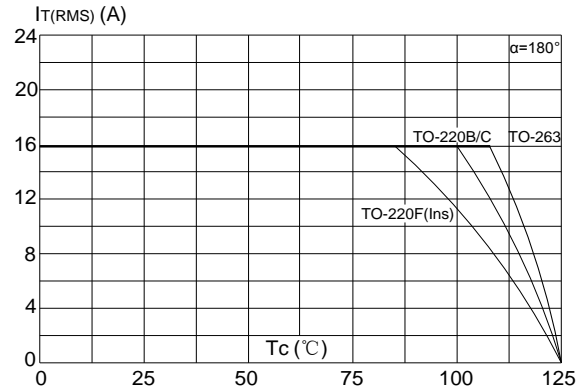

**FIG.3:** Surge peak on-state current versus number of cycles

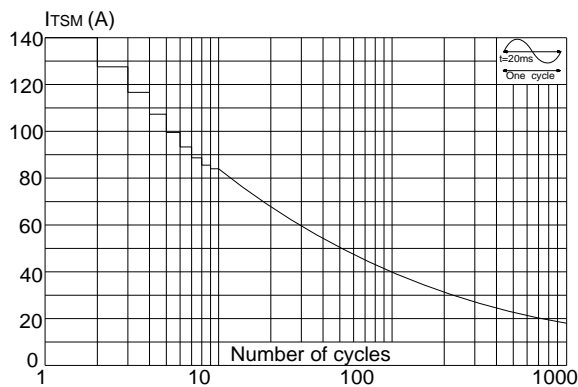

**FIG.4:** On-state characteristics (maximum values)

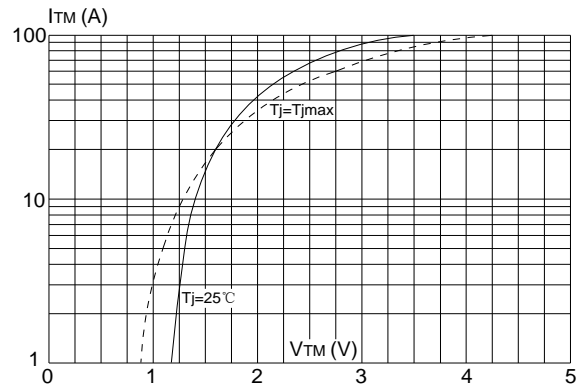

**FIG.5:** Non-repetitive surge peak on-state current for a sinusoidal pulse with width  $t_p < 20ms$ , and corresponding value of  $I^2 t$  ( $di/dt < 50A/\mu s$ )

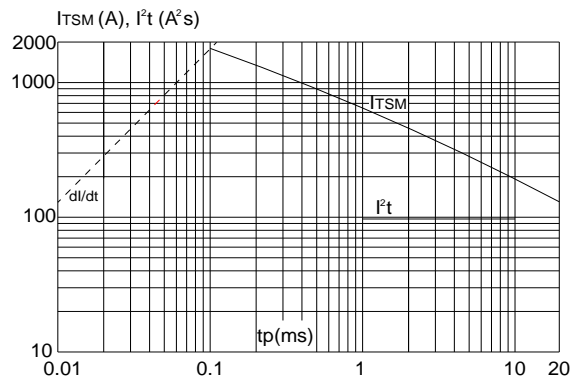

**FIG.6:** Relative variations of gate trigger current versus junction temperature

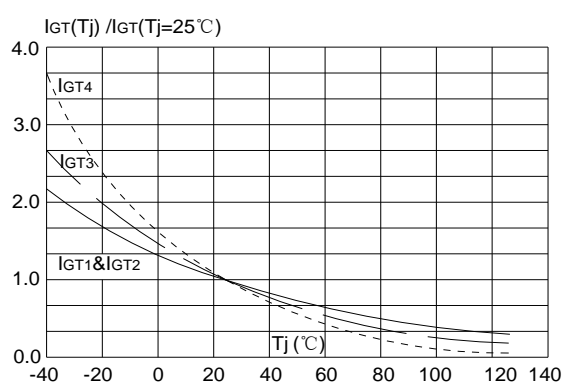

**FIG.7:** Relative variations of holding current versus junction temperature

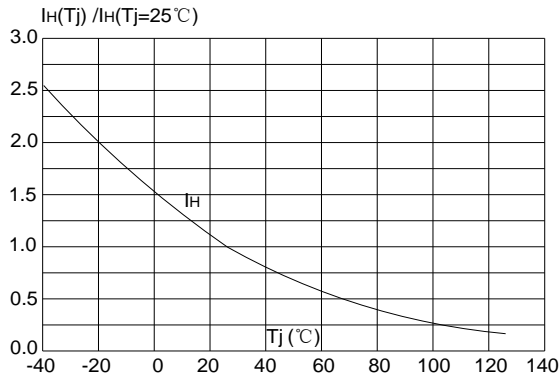

**FIG.8:** Relative variations of latching current versus junction temperature

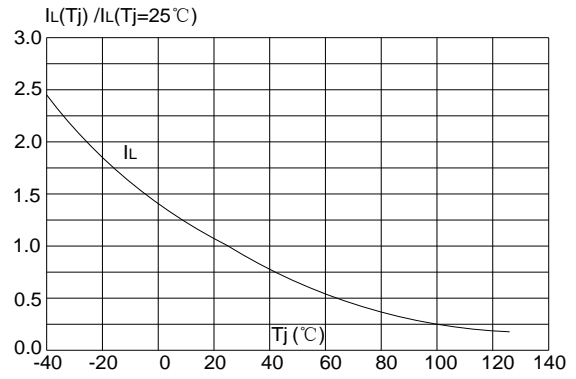

**Package Mechanical Data :**

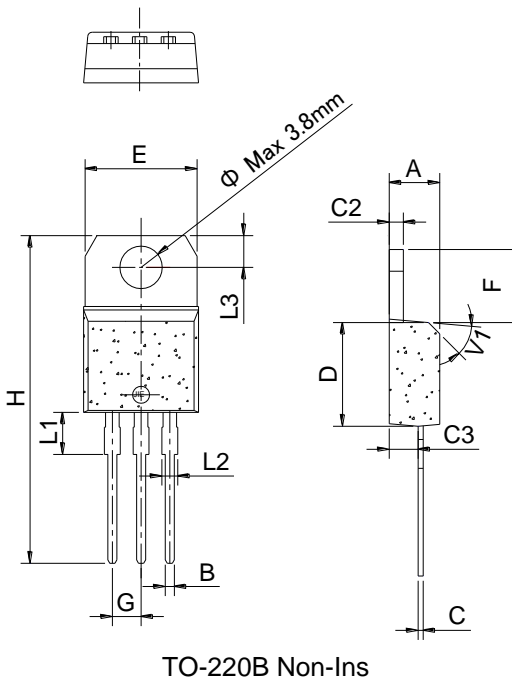

Ref.	Dimensions					
	Millimeters			Inches		
	Min.	Typ.	Max.	Min.	Typ.	Max.
A	4.40		4.60	0.173		0.181
B	0.61		0.88	0.024		0.035
C	0.46		0.70	0.018		0.028
C2	1.21		1.32	0.048		0.052
C3	2.40		2.72	0.094		0.107
D	8.60		9.70	0.339		0.382
E	9.60		10.4	0.378		0.409
F	6.20		6.60	0.244		0.260
G		2.54			0.1	
H	28.0		29.8	1.102		1.173
L1		3.75			0.148	
L2	1.14		1.70	0.045		0.067
L3	2.65		2.95	0.104		0.116
V1		45°			45°	

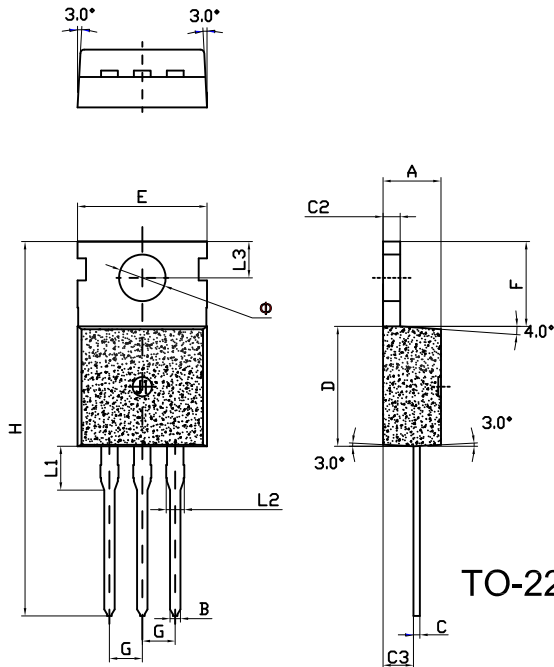

TO-220C

Ref.	Dimensions					
	Millimeters			Inches		
	Min.	Typ.	Max.	Min.	Typ.	Max.
A	4.4		4.6	0.173		1.181
B	0.7		0.9	0.027		0.035
C	0.45		0.6	0.018		0.024
C2	1.23		1.32	0.048		0.052
C3	2.2		2.6	0.086		0.102
D	8.9		9.9	0.350		0.390
E	9.9		10.3	0.390		0.406
F	6.3		6.9	0.248		0.272
G		2.54			0.1	
H	28.0		29.8	11.0		11.7
L1		3.2			0.126	
L2	1.14		1.7	0.045		0.067
L3	2.65		2.95	0.104		0.116
Φ		3.6			0.142	

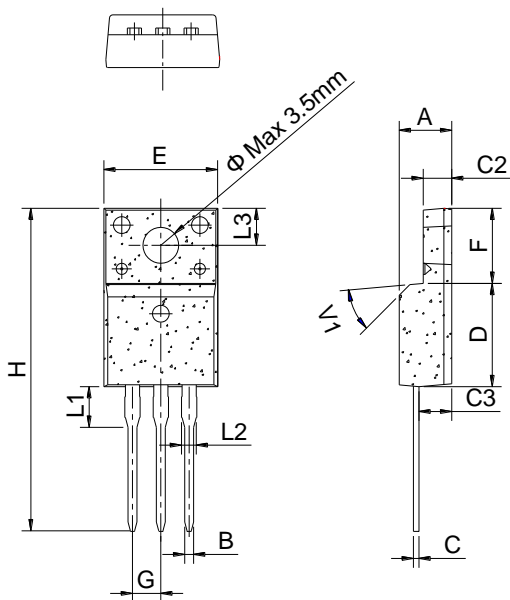

TO-220F Ins

Ref.	Dimensions					
	Millimeters			Inches		
	Min.	Typ.	Max.	Min.	Typ.	Max.
A	4.40		4.80	0.173		0.189
B	0.74	0.80	0.83	0.029	0.031	0.033
C	0.48		0.75	0.019		0.030
C2	2.40		2.70	0.094		0.106
C3	2.60		3.00	0.102		0.118
D	8.80		9.30	0.346		0.366
E	9.70		10.3	0.382		0.406
F	6.40		7.00	0.252		0.276
G		2.54			0.1	
H	28.0		29.8	1.102		1.173
L1		3.63			0.143	
L2	1.14		1.70	0.045		0.067
L3		3.30			0.130	
V1		45°			45°	

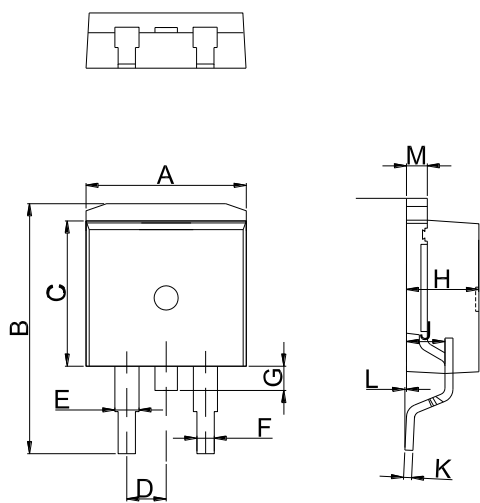

TO-263

Ref.	Dimensions					
	Millimeters			Inches		
	Min.	Typ.	Max.	Min.	Typ.	Max.
A	9.90		10.20	0.390		0.402
B	14.70		15.80	0.579		0.622
C	9.4		9.6	0.37		0.378
D		2.54			0.100	
E	1.20		1.40	0.047		0.055
F	0.75		0.85	0.029		0.033
G			1.75			0.069
H	4.40		4.70	0.173		0.185
J	2.30		2.70	0.091		0.106
K	0.38		0.55	0.015		0.022
L	0	0.10	0.25	0	0.004	0.010
M	1.25		1.35	0.049		0.053